



DrySyn heating blocks
Clean, safe synthesis

Asynt 

New ideas... better solutions

The DrySyn range of heating blocks enables clean, safe synthesis for single or multiple reactions. It was developed by chemists and included valued contributions from such organisations as the Department of Chemistry, Cambridge University. DrySyn is established as proven technology, chosen by key pharmaceutical companies, Biotechs, CRO's and universities among many others.

No longer do the hazards of hot silicon oil baths or mantles have to be a necessary health and safety risk in every laboratory, while new additions to the DrySyn family have ensured that more and more users can enjoy the clear-cut benefits of this exceptional technology.

If you require further information about any of the featured items, or wish to discuss a specific application, our team of experts will be pleased to assist you. You can also visit our website at www.drysyn.com



"Our DrySyn units have proved themselves with their ability to outperform the heat-conducting properties of oil baths. They pose a far lower fire risk and their use makes the clean-up of glassware far easier, as there is no residual oil contamination on the outside of the flasks. They fit our policy of ensuring a safer, cleaner, healthier working environment".

Dr Pete Maunder, Tripos Discovery Research



Putting an end to oil bath safety hazards

Historically, chemists have used oil baths or heating mantles to heat reactions in round-bottomed flasks. However, oil baths have caused many fires in chemistry labs and, as the flashpoint of silicon oil decreases with repeated use, the risk of fire becomes even greater as time passes. The cleaning up of inevitable oil spillages is very time consuming. Oil baths can also emit toxic fumes and polymerise with continuous heating.

Driven by increased awareness of safety and productivity demands, the requirement for an alternative resulted in the introduction by Asynt of its DrySyn heating block range.

It is now the proven alternative to oil baths and mantles, guaranteeing clean, safe synthesis, while achieving the highest possible heating performance using anything from 1 ml vials to 5000 ml flasks.

As many users will testify, DrySyn heating blocks have made a significant contribution to laboratory safety, bringing an impressive list of benefits to users:

Safety

- Safe temperature ramping to 250°C
- Safe and easy removal of flasks from heat source
- Low well design prevents cracking of glassware
- Chemical and solvent resistant
- Secure lifting handles ensure safe removal from heat source

Versatility

- Accommodate the full range of standard round bottomed flasks
- Compatible with any hotplate stirrer
- Components available separately or as cost-effective kits
- Compatible with multi neck flasks
- Modular system with small footprint
- Full range of accessories
- Equal or better heating performance than silicon oil

Ease of use

- Excellent reaction visibility due to shallow well and clear anodised finish
- Quicker and easier glassware cleaning

Assurance

- Environmentally friendly
- Supported by expert service and advice from the world leaders

"DrySyn has totally eliminated our use of oil baths for all common laboratory-scale chemical reactions. The DrySyn MULTI-M range has considerably improved the efficiency and safety of our laboratory. It is no exaggeration to say that the DrySyn range has transformed the way we carry out our research within an academic laboratory".

Dr David Lindsay, University of Bristol

DrySyn single position heating blocks

Inserts adapt the block for smaller flasks (DrySyn Classic and MAXI)



Heat resistant handles for safe and easy lifting

Solid aluminium base accommodates large flask

Fit standard hotplate stirrers, including IKA and Heidolph



Powerful stirring and high reaction visibility

Probe hole for temperature control

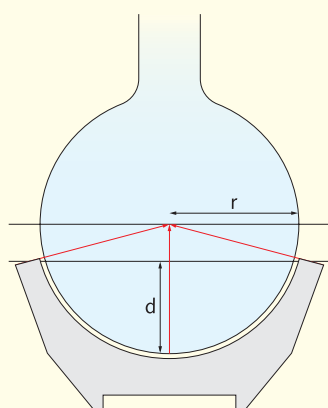

DrySyn well design safeguards flasks

The DrySyn shallow well design not only increases reaction visibility, but also minimises the possibility of glass fractures.

The diagram shows that the rim of the DrySyn base is well below the centre line of the flask. Any crushing forces (shown in red) will act normally and be directed towards the centre of the flask, tending to push it upwards.

DrySyn single position heating blocks

One reaction at a time...

For single reactions, the DrySyn Classic, MAXI and SuperMAXI heating blocks provide the ideal solution.

- 50 ml to 5000 ml flasks
- Superior reaction visibility
- Powerful, efficient stirring
- Unique, heat resistant lifting handles as standard

DrySyn Classic

For 50 ml - 1000 ml

- Classic base holds a 1000 ml flask, with four inserts for smaller sizes
- Base and inserts can be ordered as separate components, if required

Ordering information

ADS1 DrySyn Classic kit consisting of 50 ml, 100 ml, 250 ml and 500 ml inserts and 1000 ml base



DrySyn Classic heating performance compared to oil bath

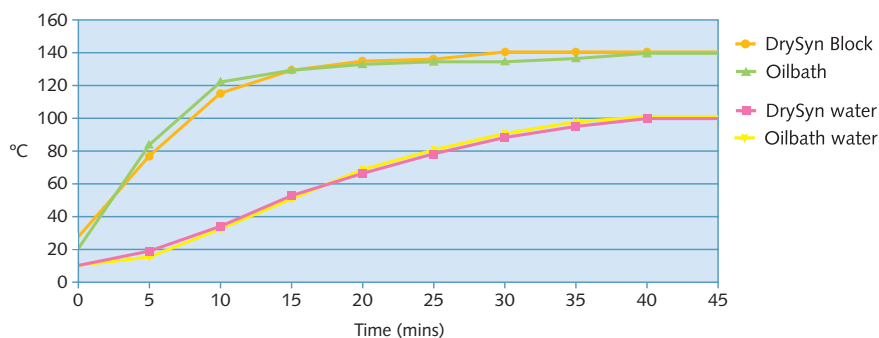

In performance tests, the DrySyn Classic and an oil bath showed nearly identical heating rates and solvent temperature profiles. This proved that there is no need to change chemistry protocols.

DrySyn MAXI

For 2000 ml and 3000 ml

- MAXI base holds a 3000 ml flask, with 2000 ml insert

Ordering information

ADS2 DrySyn MAXI kit consisting of 3000 ml base, with 2000 ml insert

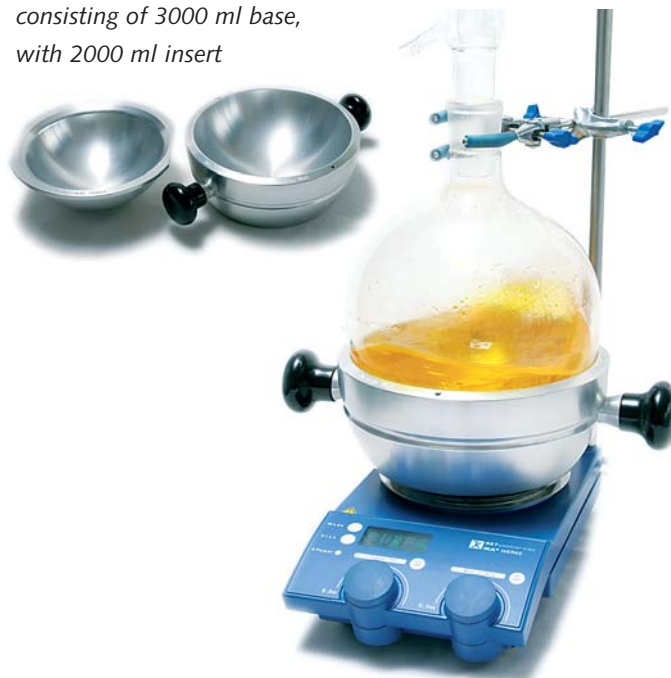

DrySyn SuperMAXI

For 5000 ml scale

Ordering information

ADS4 DrySyn SuperMAXI



DrySyn MULTI parallel heating blocks

One block, multiple options

Using a standard DrySyn MULTI base, this parallel heating block kit enables up to 12 reactions to be performed simultaneously.

- Choose from 1 ml vials up to 500 ml flasks by selecting from the range of inserts
- Components can be ordered separately or as cost-effective kits
- Optional safety lifting handle

The DrySyn MULTI concept



One reaction –
using central
position



Three reactions –
configure any
combination
of flask sizes



Twelve reactions

DrySyn MULTI reaction vial inserts are available for:

- Wheaton reactor vials up to 20 ml
- Microwave tubes
- Boiling tubes
- Custom sizes also available

Please see price list for sizes and ordering information

DrySyn MULTI

For 1 ml - 100 ml

- DrySyn MULTI - up to 3 x 100 ml flasks or a single 250 ml or 500 ml insert in the central position
- DrySyn MULTI inserts are compatible with all bases

Ordering information

ADS3 DrySyn MULTI kit consisting of base, 3 x 25 ml, 3 x 50 ml and 3 x 100 ml inserts



DrySyn MULTI-M

For 1 ml - 250 ml

- DrySyn MULTI-M - up to 3 x 250 ml flasks
- Single 500 ml insert fits in central position

Ordering information

ADS5 DrySyn MULTI-M kit consisting of base, 3 x 100 ml and 3 x 250 ml inserts



DrySyn MULTI-S

For 1 ml - 500 ml

- DrySyn MULTI-S - up to 3 x 500 ml flasks

Ordering information

ADS6 DrySyn MULTI-S kit consisting of base, 3 x 250 ml and 3 x 500 ml inserts



Accessories

DrySyn MULTI clamps

Three flasks or condensers can be held securely with a single DrySyn MULTI 3-position clamp.

- Space saving
- Allows safe and easy removal from heat source
- Can be used independently – for example, to clamp three flasks over an ice bath

Ordering information

ADS3-C MULTI clamp
ADS5-C MULTI-M clamp
ADS6-C MULTI-S clamp



Asynt magnetic hotplate stirrer and temperature controller

The Asynt magnetic hotplate stirrer complements the DrySyn range.

- Reaches temperatures of up to 300°C
- Socket for optional electronic temperature control unit

Ordering information

ADS-HP1 Hotplate stirrer
ADS-TC1 Optimal temperature controller



Options

Flat base

All DrySyn models can be supplied with a flat base and removable pins, allowing them to accommodate square topped hotplates and very large hotplates.



DrySyn MULTI reaction vials

Asynt supplies a range of Wheaton V-vials that are compatible with DrySyn MULTI 4-position vial inserts. Vials are available in a graduated or non-graduated form.

Please see price list for ordering information



Safety lifting handle

Optional safety lifting handle, compatible with all DrySyn MULTI units manufactured post October 2006.

Please see price list for ordering information



Stirrer bars

Recommended PTFE magnetic stirring bars for all DrySyn MULTI units.

Ordering information

ADS3-SB-15 Stirrer bar for 10 ml flasks
ADS3-SB-25 Stirrer bar for 25 ml and 50 ml flasks
ADS3-SB-30 Stirrer bar for 100 ml to 500 ml flasks



Pear shaped flasks

Standard DrySyn components are designed to fit round bottomed flasks. However, pear shaped flasks can be catered for if required.

Special requirements

Custom inserts for a range of flask shapes and sizes are available. Please contact us to discuss your requirements.

Asynt invests consistently in developing its own apparatus for chemists and supporting novel chemistry technologies from partner companies. We welcome input from all interested parties, so if there is a product that you would like to see developed, please let us know.

DrySyn is manufactured in the UK by Asynt Ltd.

Contact us for:

- Worldwide distributor information
- Quote enquiries
- Demonstrations in your lab by chemistry specialists
- Technical support from qualified chemists



Asynt

Asynt Ltd

Unit 29 Hall Barn Road Industrial Estate Isleham Cambridgeshire United Kingdom CB7 5RJ
Telephone: +44 (0)1638 781709 Fax: +44 (0)1638 781706 sales@asynt.com www.drysyn.com